

GABRO

COMBINED APERTURE CUTTER AND HOLE PUNCHER

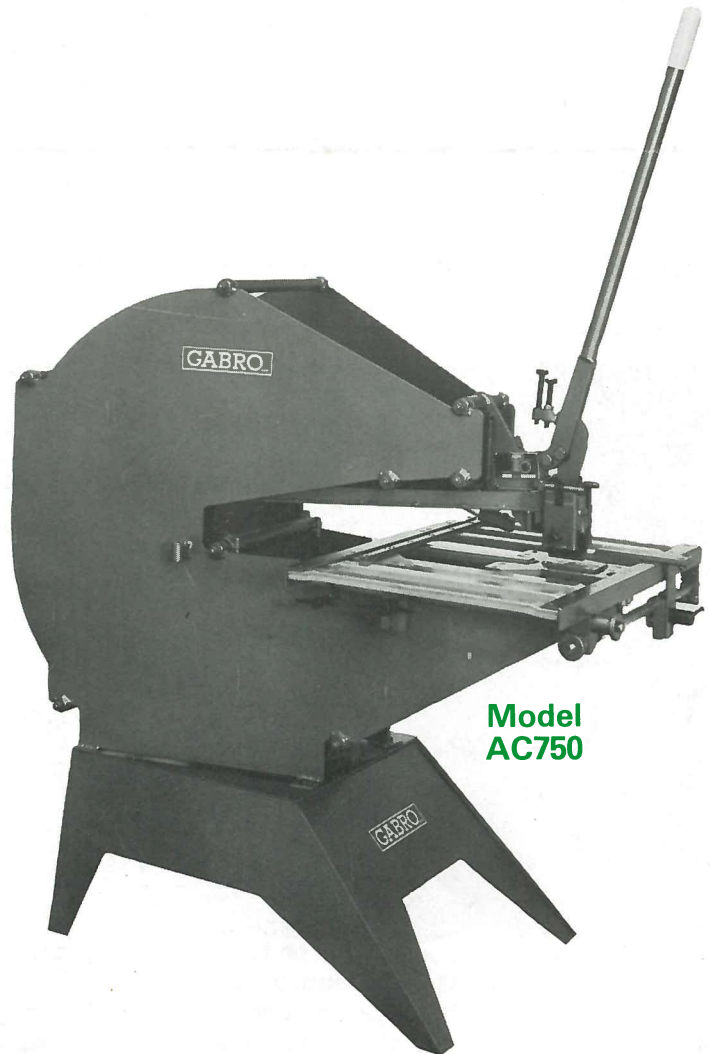

Model
AC450



Model
AC750

GABRO

is a Registered Trade Mark

GABRO models AC450 and AC750 are specifically designed for cutting openings and punching holes in sheet metals as well as in many other materials used in industry and for craft and technical teaching. They are built in accordance with well established engineering practice and are capable of producing a great variety of high quality work not previously possible on one machine at such low cost. A comprehensive range of standard tooling is available, while shaped punches and dies can be manufactured to special order.

A table indicating the punching capacities of these machines is shown on page 7 of this brochure. These capacities are identical for models AC450 and AC750, the critical distinction between the two machines being solely the different throat depths and therefore size of material they will accommodate. The AC450 has a throat depth of 450mm (17.7") and the depth of the AC750 is 750mm (29.5"). The throat depth is measured from the back of the standard 50 x 6mm blade to the apex of the throat in the side plates. Both machines are supplied with robust fabricated pedestal stands. For easy manoeuvring nylon wheels are fitted to the AC450 and this machine is also provided with a scrapbox.

GABRO APERTURE CUTTING AND HOLE PUNCHING MACHINES incorporate many unique and practical features, the most important of which are protected by British and Foreign Patents:

- Heavy and expensively machined castings often considered necessary to maintain alignment between the Punch and Die, have been abandoned in favour of a much less costly triangulated steel structure designed so that deformation due to applied load cannot cause misalignment between Punch and Die.
- The blade or punch is mounted at the apex of a substantial triangulated "Delta" plate which pivots on loaded ball bearings and moves in a tightly held arc. With a blade/die set-up this provides the progressive blanking action which has proved so successful on Gabro Guillotine/Notchers.
- The workpiece is stripped from the blade or punch by a range of pivoting strippers with quickly interchangeable feet which are also adjustable for clearance over the workpiece.
- Dies are mounted on Bolsters fitted with hardened location plates which are very easily set and unique Gabro design ensures exact realignment between punch and die whenever tools are changed.

Two distinct types of Punch and Die combination can be used:

As an Aperture Guillotine

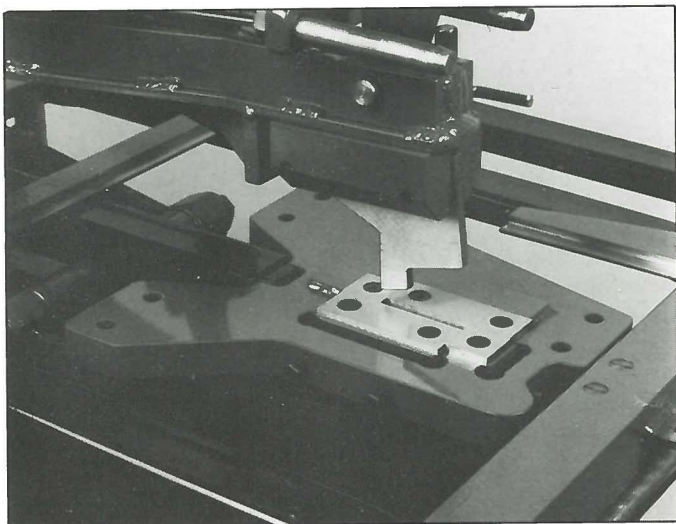

Each machine is fitted as standard with a 50 x 6mm heeled blade and 4 piece adjustable die on type 'A' Bolster. One stroke cuts a slot 50 x 6mm in up to 3.2mm thick mild steel. Longer slots are cut by successive strokes and shorter ones by using the Stop Screws as illustrated on page 5. Shorter and thinner blades are also available.

As a Punching Machine

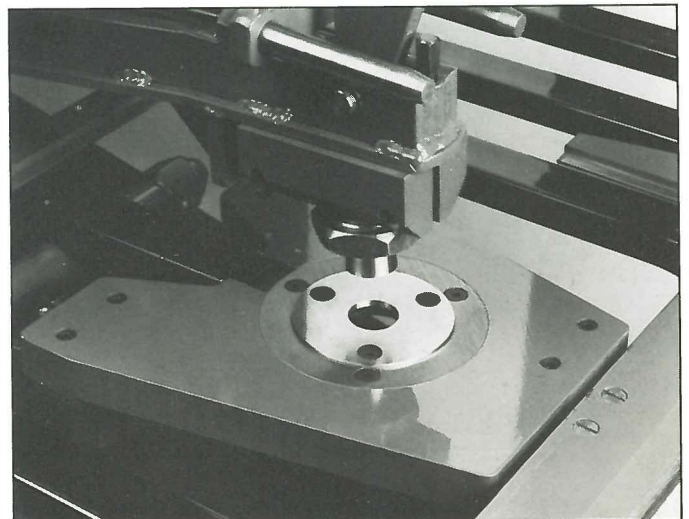

Type 'B' Bolster is available together with a range of circular punches and dies for holes from 2 to 75mm dia. Punches and dies align automatically after initial setting of the Bolster. Special tools can be supplied for larger diameter holes.

The dual nature of the machine is a vital asset and some special punch/die adaptors are available so that proprietary makes of punch/die combinations can be used. Changing from one Bolster set-up to another takes only a few minutes and the following illustrations show how the top tools and Bolster are located and correct realignment of tools achieved, however often changed:

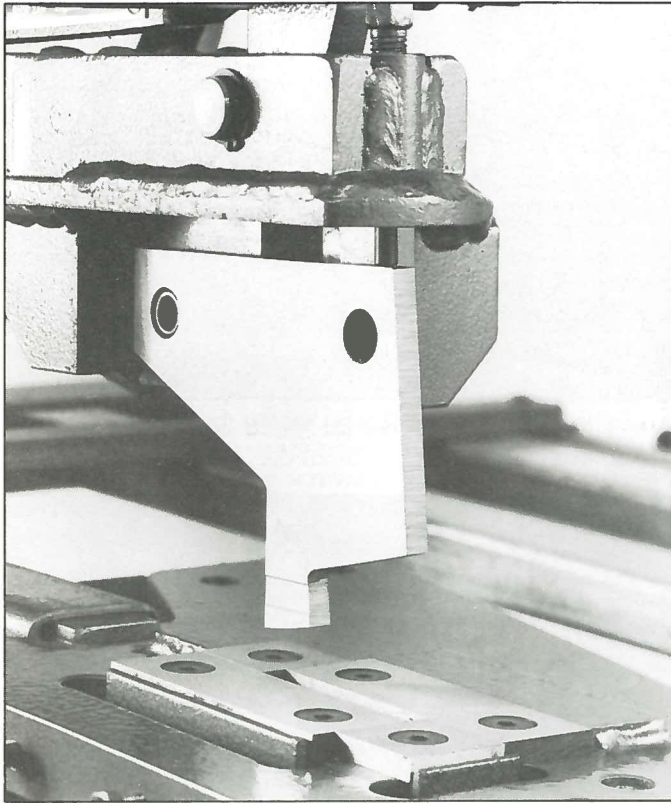

The blade pivots on a bush with adjustment at the front provided by a vertical screw. This arrangement gives fine adjustment for correct clearance between the back of the blade and the die, whilst correct clearance at the front of the blade is controlled by adjustment of the die itself.

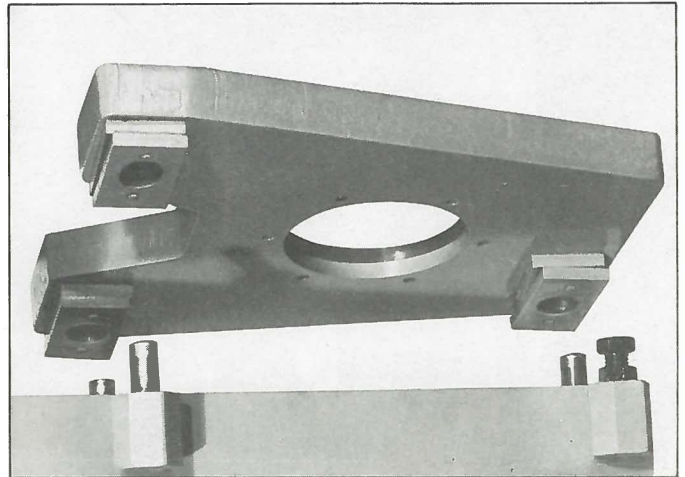

Bolsters are provided with three ground locating plates which fit exactly on three hardened pegs. They are secured by clamping plates with screws tightened from the upper surface. With the bolster in place and the screws loosened, the tools can be aligned and after the screws have been re-tightened the bolster can be lifted off and replaced repeatedly in perfect alignment. The fourth corner rests on an adjustable screw to prevent rocking.

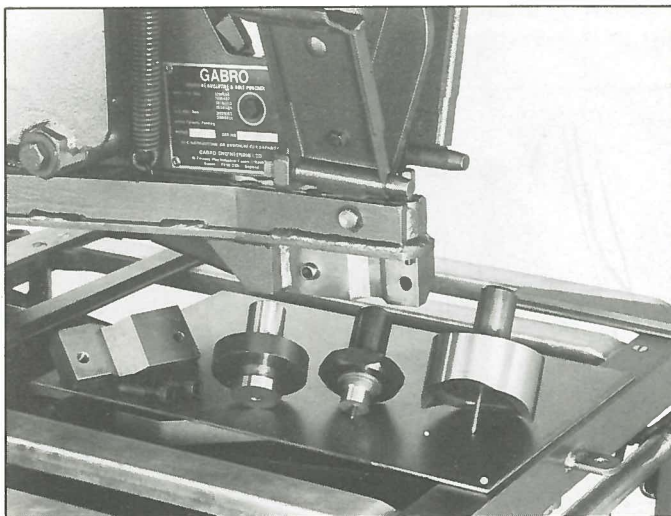

With the blade removed, the top tool clamping block has two split bores which permit exact positioning of punch holders of either 1" or 25mm dia. Square ground punches are set at 2° to provide "shear". For extra punching capacity "claw shear" punches are available.

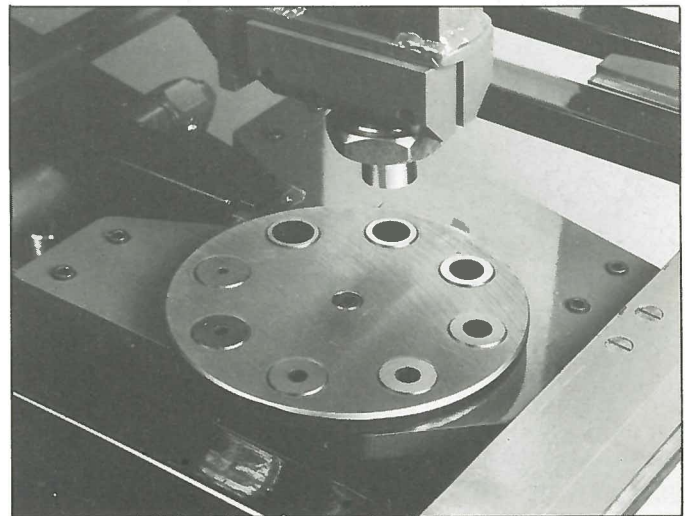

Where regular punching of different size holes up to 18mm dia is carried out, a special Bolster and Turret assembly is available, which enables rapid changeover from one hole size to another.

STRIPPER FEET

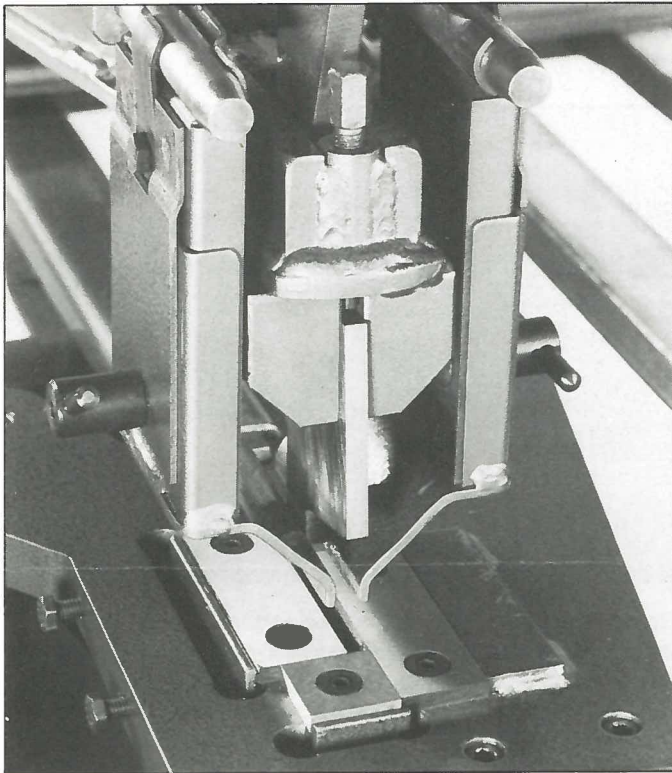

All machines are supplied with a pair of stripper main plate assemblies fitted with stripper feet for flat blades.

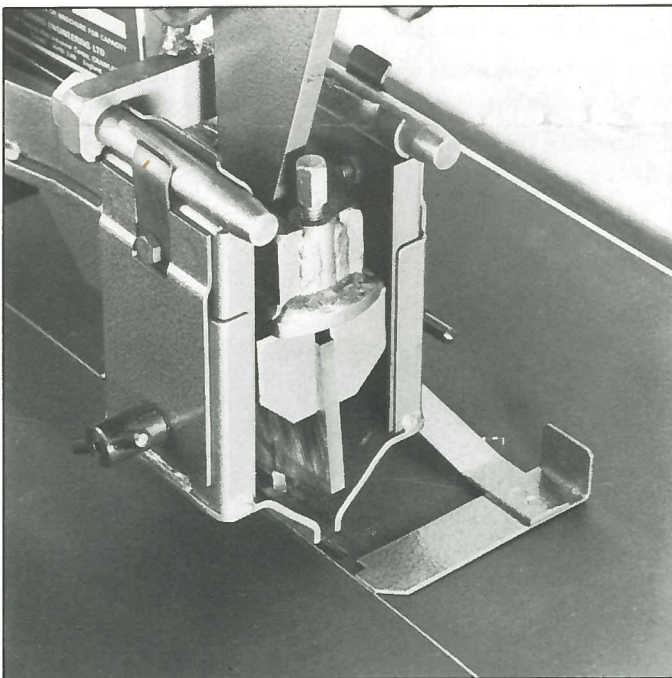

A Line Guide is also fitted, for use when fences are impractical. The nib, seen here just touching the line, is arranged to indicate the exact position of both the sides and front end of the die, usually hidden by the work-piece. When not in use it can be swung away and is relocated by an accurate ball plunger.

▶ The standard range of tooling includes a Corner Notching Bolster Assembly and Punch. Equal notches up to 50 x 50mm can be punched in max. 2.0mm mild steel.

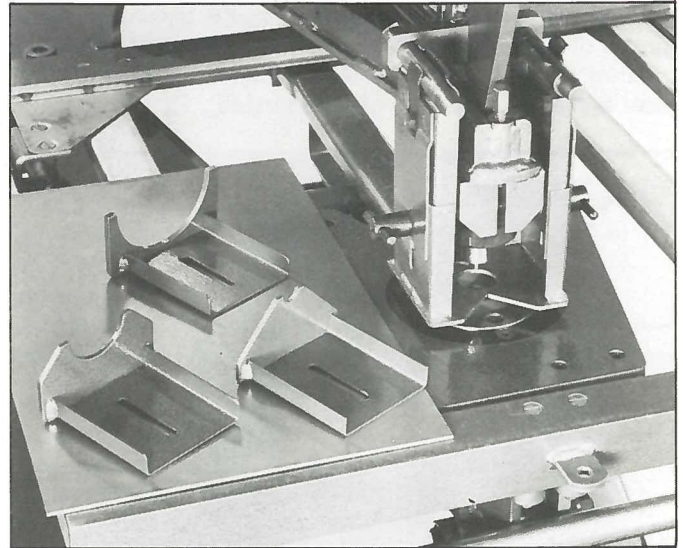

A selection of stripper feet for round or square punches is also available for up to 75mm dia holes.

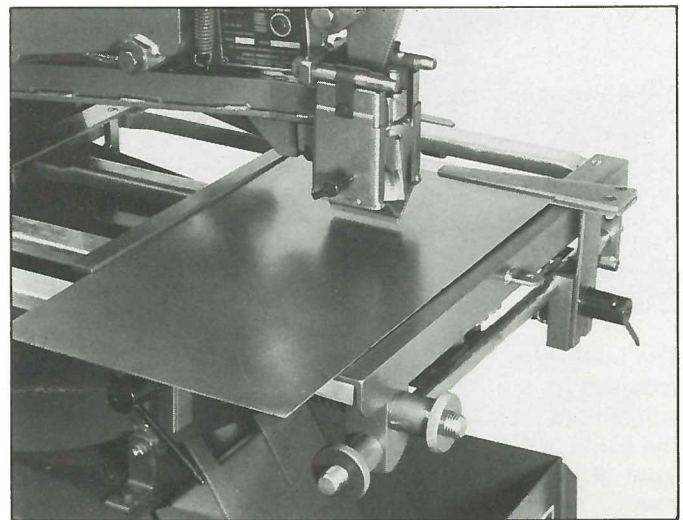

Side and Rear Fences are fitted to all machines as standard, each with a quick release for rough positioning. Fine adjustment is provided by a knurled handwheel and once set up the fences can be locked in position by a tommy nut clamp. An Extended Side Fence is available for use with larger sheets of material.

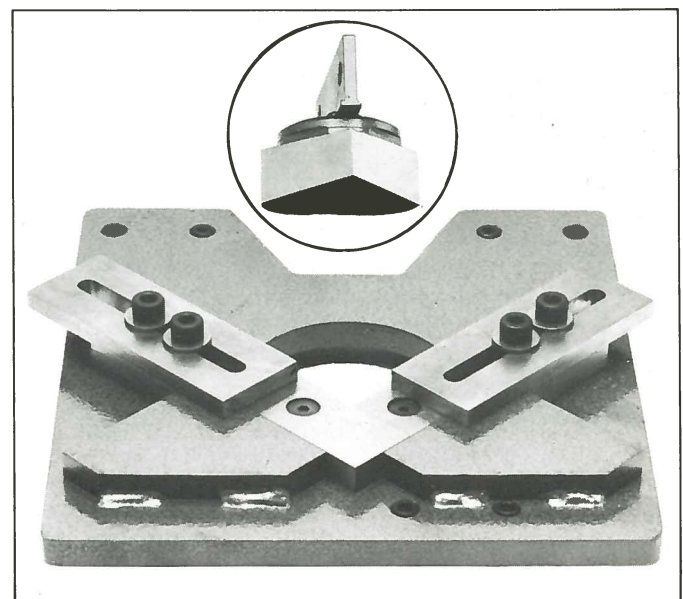

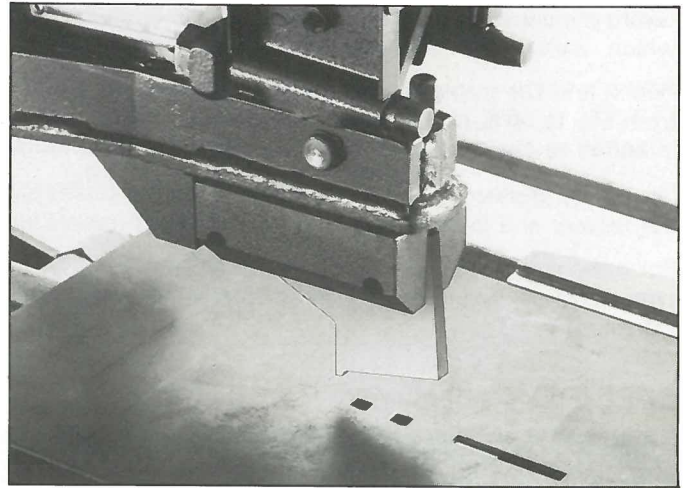
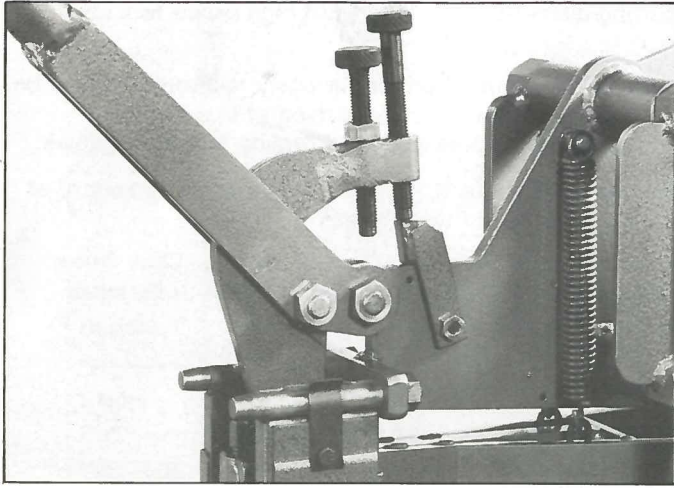

Two knurled Stop Screws control the depth of entry of blades and punches into the dies. The block on which the longer screw abuts is pivoted so that it can be swung in or out of use instantly. The setting illustrated is typical for making a small slot where only the top of the blade is required to enter the work, which is then turned and the slot completed from the other end.

The shorter of the two screws is used mainly to ensure the blades and punches enter the dies no further than is necessary to cut the holes. This provides easy stripping and avoids damage to tools which could occur if blades or punches enter too far.

The CENTRE LOCATOR

This accessory has many uses and consists of a pair of adjustable telescopic arms with pivoting spigots which drop into corresponding sockets on each side of the machine. The head plate has a screw on which the work piece can pivot or rotate and the device provides a means of establishing a centre point wherever needed.

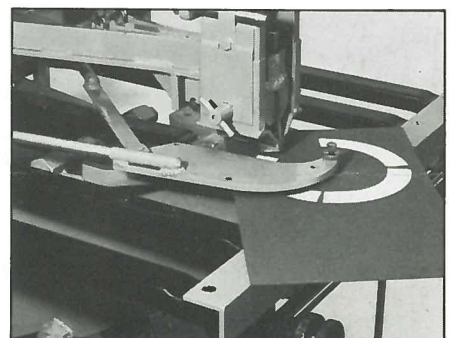
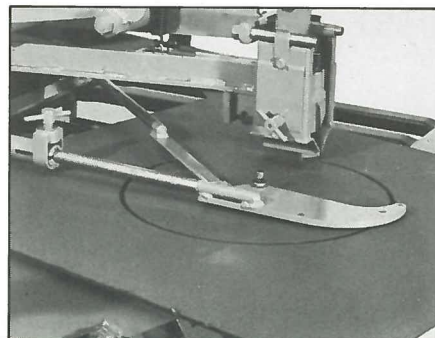
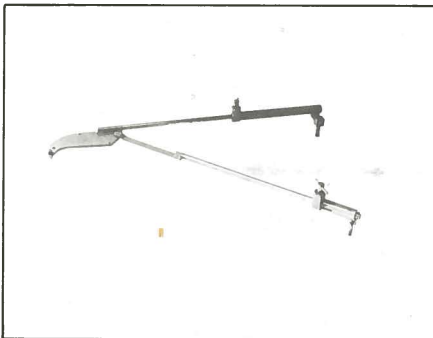

Circumferences finish as a series of short flats and this is generally acceptable without further work, as the out-of-round, using a 25 x 6mm blade, is only 0.5mm at 300mm dia. This is a quick way to cut out large holes and discs to about 800mm dia and in up to 3.2mm mild steel. Radial slots are also simple to achieve.

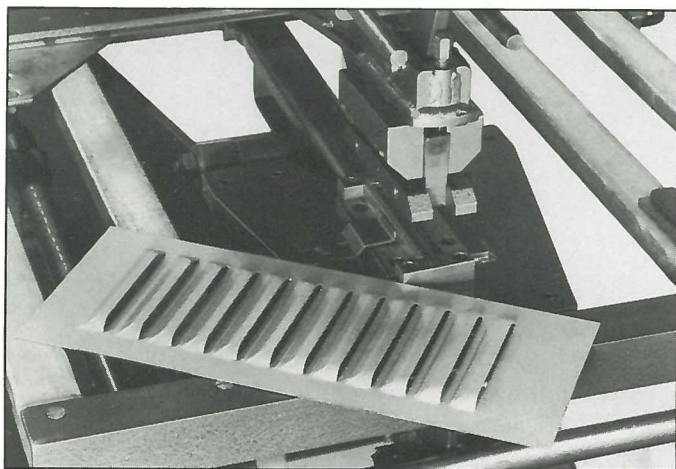

Making Louvres.

A special Bolster Assembly and Top Forming Tool produces a very neat louvre 100mm long by 4.5mm air space and can be formed in up to 1.2mm mild steel (3mm aluminium). Tools for shorter louvres can be supplied to special order.

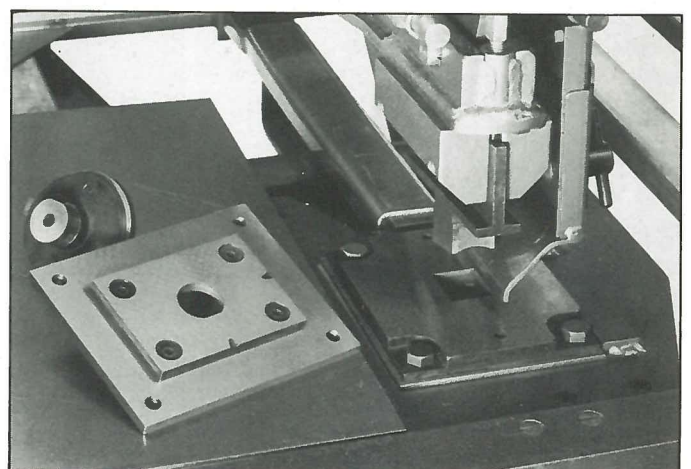

Special Tools

Rectangular, Square or Shaped punches from 1.5mm to 25.0mm wide and up to 65mm long with corresponding dies can be made to special order. Punches with square ends, radiused ends or radiused corners can be supplied and we are also able to manufacture special purpose tools for corner radiusing.

Gabro machines require a minimum of maintenance and all cutting elements are made from high grade tool steel which, with careful use, can be made to last for years.

Punch and Die clearance can affect the cleanness of cut and the effort required and is variously recommended to be from 5% to 10% of the stock thickness. However, some form of compromise must be arrived at in a machine intended to cut a wide range of materials in a wide range of thicknesses, so that standard tooling is set as follows:

On the 'A' Bolster set-up for aperture cutting the dies are easily adjustable but 0.1mm per side is set as standard at the factory and is satisfactory for the most commonly worked middle range of thicknesses.

For punching circular holes a fixed compromise has been set at 0.3mm on the diameter, although for Claw Shear type punches, which are generally used in thicker materials, 0.5mm on the diameter has been found to be more satisfactory.

SPECIFICATIONS



Model AC450

Pedestal mounted, wheeled
Scrapbox
Table, 590 x 590mm
Side Fence, Rear Fence
Line Guide
Fitted with 'A' Bolster assy
50 x 6mm heeled blade and
die set
Pair of stripper main plates
and feet
Operating instructions

Dimensions:

Width	590mm
Height (handle up)	1930mm
Height (handle down)	1270mm
Weight	133kg

Model AC750

Pedestal Mounted
Table 800 x 600mm
Side Fence, Rear Fence
Extended Rear Fence
Line Guide
Fitted with 'A' Bolster assy
50 x 6mm heeled blade and
die set
Pair stripper main plates
and feet
Operating instructions

Dimensions:

Width	800mm
Height (handle up)	1930mm
Height (handle down)	1460mm
Weight	216kg



Patent Nos. UK 1391496
1415457
1536323
1536324

USA 3851553
3996831

CAPACITIES — applicable to both machines

Material	Guillotining	Punching — up to 75mm diameter																							
		Thickness in mm																							
		0.5	0.6	0.7	0.9	1.2	1.6	2.0	2.6	3.0	3.2	4.0	5.0	6.0											
Mild Steel	3.2mm	75	75	75	75	75	75	75	75	50	75	16	75	12	45	10	16	9	—	6	—	—	—	—	
Stainless*	3.0mm	75	75	75	75	75	75	50	75	30	75	25	75	10	55	5	—	—	—	—	—	—	—	—	
Aluminium	5.0mm	75	75	75	75	75	75	75	75	75	75	75	75	75	75	75	75	75	75	50	55	9	—	6	—
Copper	4.0mm	75	75	75	75	75	75	75	75	65	75	25	75	18	75	16	50	16	40	8	—	—	—	—	
Brass	3.2mm	75	75	75	75	75	75	75	75	50	75	16	75	14	55	12	45	12	—	6	—	—	—	—	
Hardboard	9.0mm	75	—	75	—	75	—	75	—	75	—	75	—	75	—	75	—	75	—	75	—	75	—	75	—

MAX DIAS. IN MM. Black figures for work with flat faced punches producing flat blanks. Green figures for work with "Claw Shear" punches giving good holes but distorted blanks. Holes up to 150mm dia. can be punched with special tools.

*All figures relate to materials of general purpose tensile strengths. Some stainless steels may be below the above capacities.

Gabro Aperture Cutting and Hole Punching machines are simple and straightforward in use, yet are capable of producing a variety of high quality work in a wide range of materials. They are invaluable wherever sheet metal is used and particularly for prototype and development work or where small production runs are required, as well as for general workshop use. They are also particularly suited for many applications in craft and technical teaching.

These are some examples of the type of work that can be produced

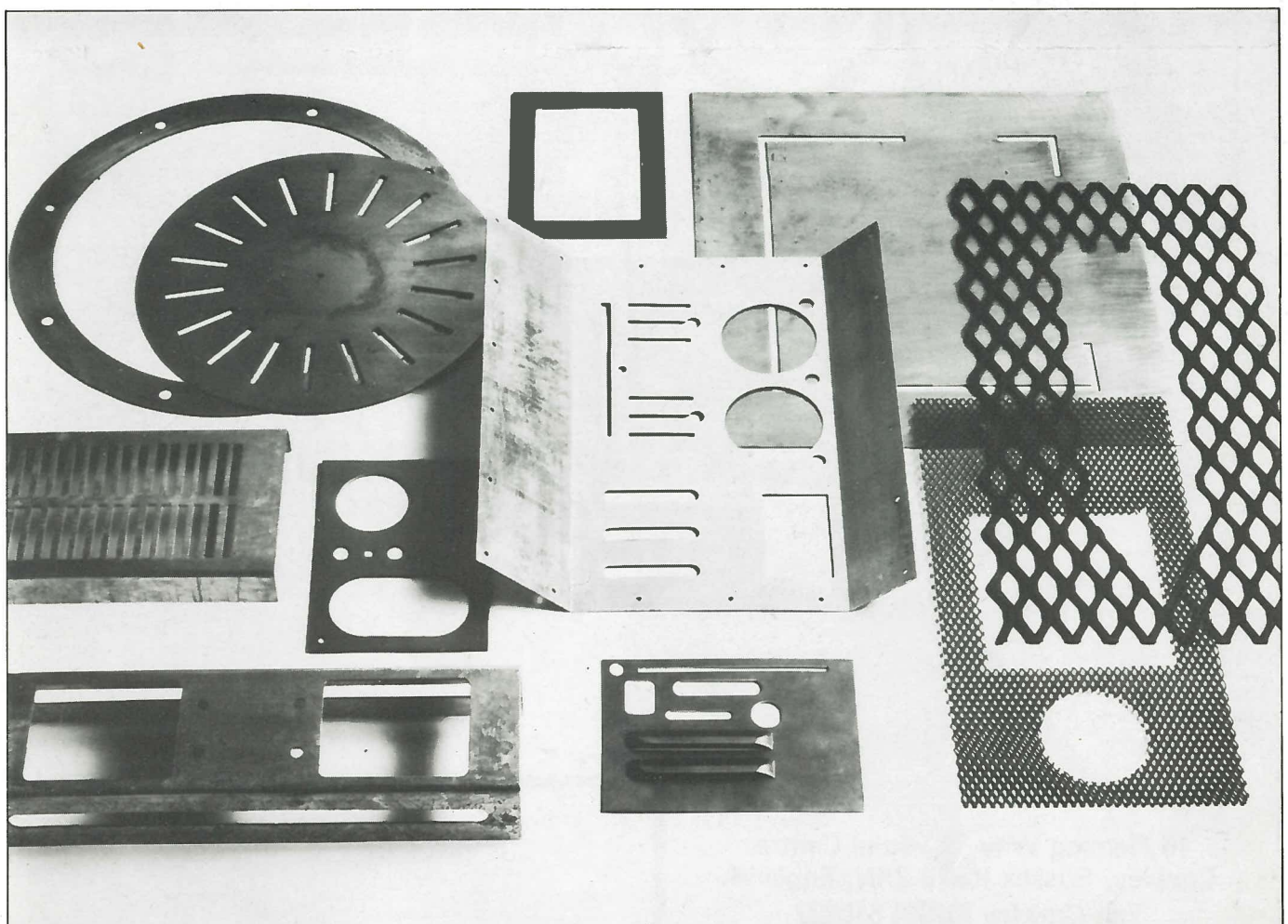

GABRO

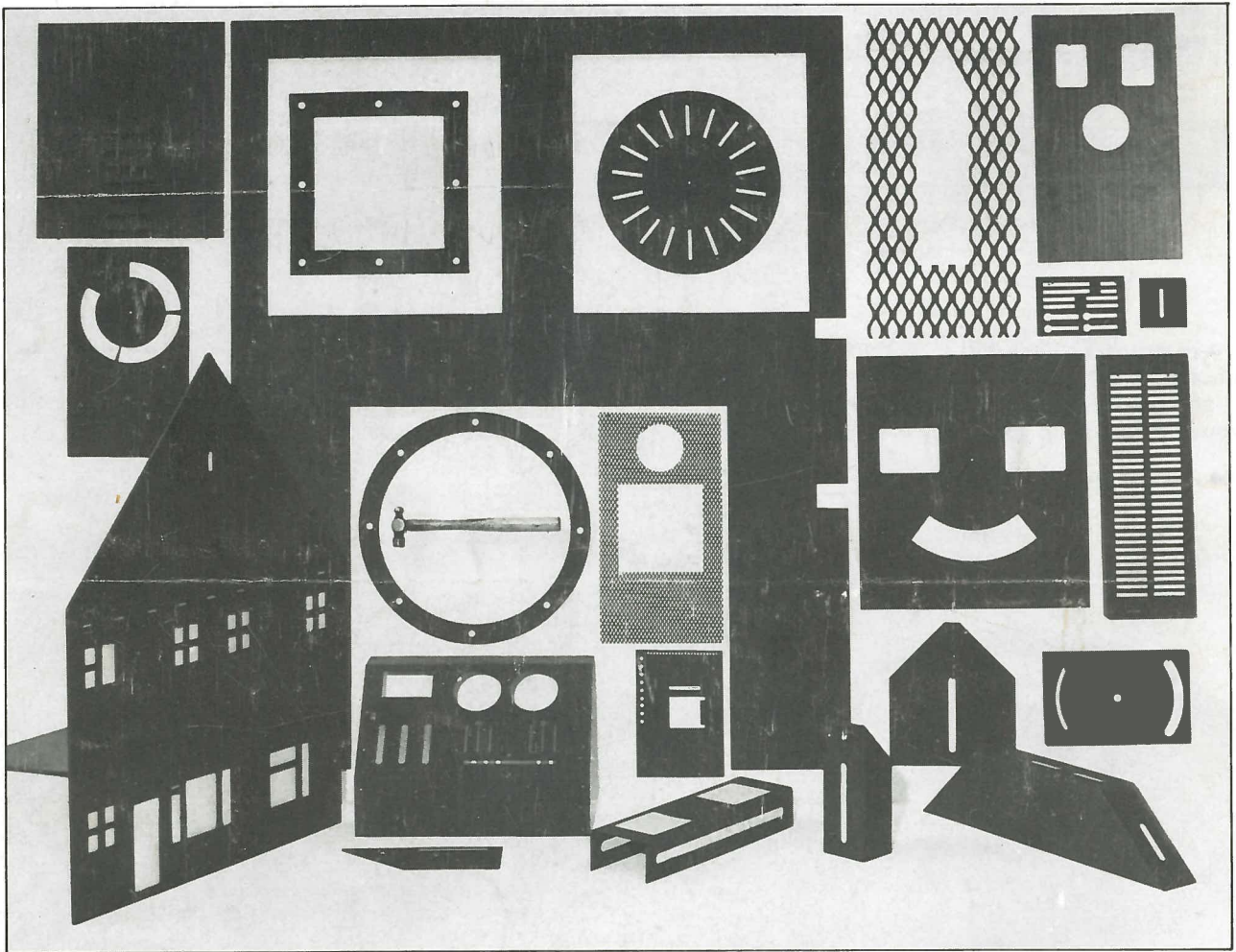

**PRECISION SHEET METAL WORKING
AT LOW COST**

GABRO ENGINEERING LTD.

16 Fleming Way Industrial Centre,
Crawley, Sussex RH10 2XN, England.

Tel: Crawley (0293) 510227

Telex: 878158